

STAINLESS STEEL

90° LIQUIDTIGHT CONNECTORS

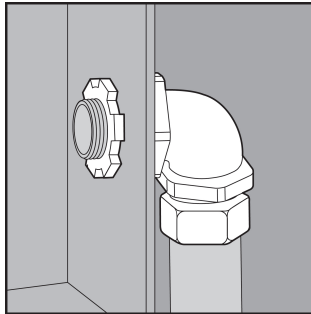
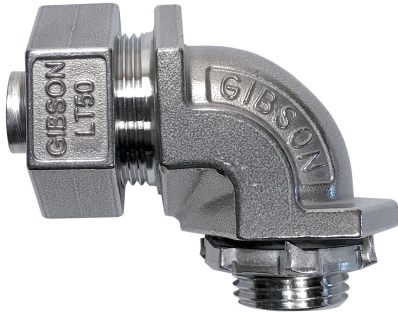

APPLICATION

- Designed for use with liquidtight conduit
- Provide a means of connecting to boxes in wet or dry locations
- Offered in three configurations: Straight, 45°, 90°
- Supplied complete with a Type 316 SS gland nut, polyethylene sealing ring, Type 316 SS ferrule, neoprene sealing gasket, and Type 316 SS locknut
- Type 316 SS inside ferrule provides extra corrosion resistance on inside of fitting (Other inside ferrules made of materials such as carbon steel may corrode easily, effecting the entire fitting.)
- Manufactured in stainless steel to help prevent corrosion
- Can be installed using ordinary hand tools and require little maintenance or repair
- Provided in a bright, polished finish that does not require touch up or painting

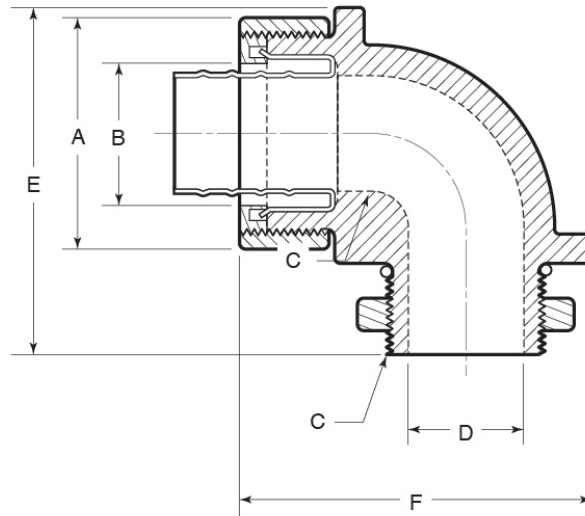

PRODUCT DETAILS

Material:

- Body: CF8M (316 SS)
- Locknut: CF8M (316 SS)
- Grounding Screw: 316 SS
- Sealing Gasket: Neoprene
- Inside Ferrule: 316 SS
- Sealing Ring: Polypropylene
- Nut: CF8M (316 SS)

Country of Origin: 100%
Made in USA

Part Number	Size	Weight/ 100 (lbs.)	Dimension (in.)					
			A	B	C	D	E	F
LT50-90	½ in.	47	1.56	0.85	½ - 14 NPT	0.62	2.14	2.40
LT75-90	¾ in.	64	1.70	1.07	¾ - 14 NPT	0.79	2.35	2.56
LT100-90	1 in.	90	2.06	1.34	1 - 11-½ NPT	1.00	2.67	2.95

